

ITM.	PART NO.	QTY.	DESCRIPTION	MATERIAL
20		1	TOP BOWL	CL30 CAST IRON
21		1	BOWL BEARING (*)	BRONZE - ASTM B-584, ALLOY 836
22		1	TOP BOWL CAP (*)	BRONZE - 926
23		1	IMPELLER (*)	BRONZE - ASTM B-584, ALLOY 865
24		4	RETAINER CAP SCREW (*)	304 SS
25		1	IMPELLER KEY (*)	304 SS
26		1	SUCTION BELL	CL30 CAST IRON
27		1	THRUST RING RETAINER (*)	BRONZE - ASTM B-584, ALLOY 865
28		1	BELL BEARING (*)	BRONZE - ASTM B-584, ALLOY 836
29			PIPE PLUG	CAST IRON
30		1	IMPELLER SHAFT	416 SS
31		1	THRUST RING (*)	304 SS
32			FASTENERS	GR 5 CARBON STEEL ZINC PLT
33		1	LIP SEAL (*)	
34		1	IMPELLER SHAFT COUPLING (*)	C-1215 CARBON STEEL
			* DENOTES RECOMMENDED SPARE PARTS	

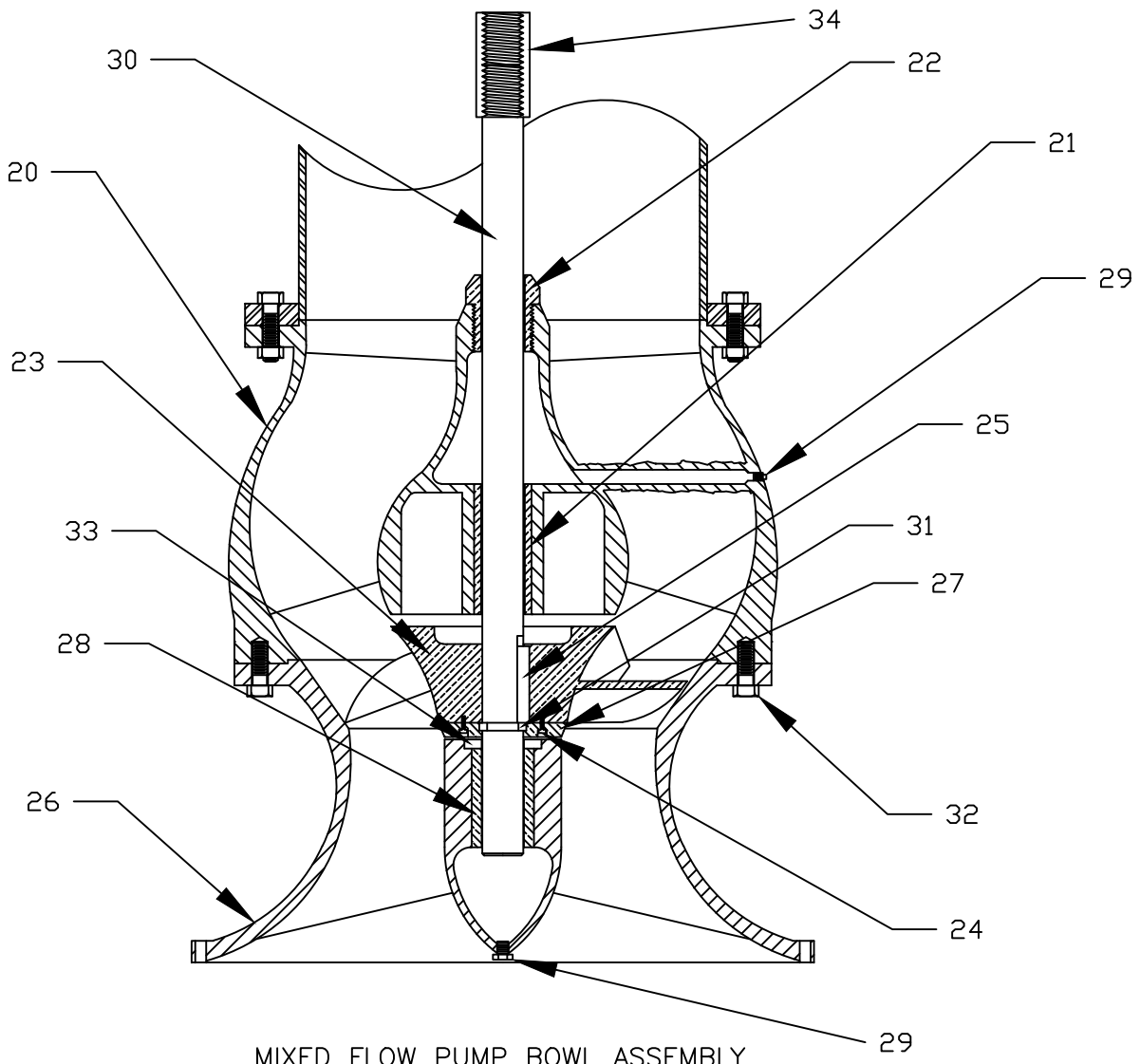

MIXED FLOW PUMP BOWL ASSEMBLY  
SINGLE STAGE - PRODUCT LUBRICATED

THE LO-LIFT PUMP COMPANY, INC 208 NORTH RAILROAD AVENUE WELSH, LOUISIANA 70591		CUSTOMER	
JOB #		CUST. ORDER#	
DATE	REV.# DATE	DATE APP.	BY
DRAWN BY	APP. BY	CAD#	