

ITM.	PART NO.	QTY.	DESCRIPTION	MATERIAL
20		1	STATOR	CL30 CAST IRON
23		1	PROPELLER (*)	MANGANESE BRONZE
24		2	PROPELLER SET SCREW (*)	300 SERIES SS
25		1	PROPELLER KEY (*)	300 SEREIS SS
26		1	SUCTION BELL	CL 30 CAST IRON
28		2	BEARING (*)	MARINE
30		1	PROPELLER SHAFT (*)	416 SS
33			FASTENERS	GR 5 GALVANIZED
39		2	RETAINING RING (*)	TEMPERED CARBON STEEL
40		1	SHAFT COUPLING (*)	C-1215 CARBON STEEL
			ROD TYPE STRAINER BASKET (OPTIONAL)	A36
			* DENOTES RECOMMENDED SPARE PARTS	

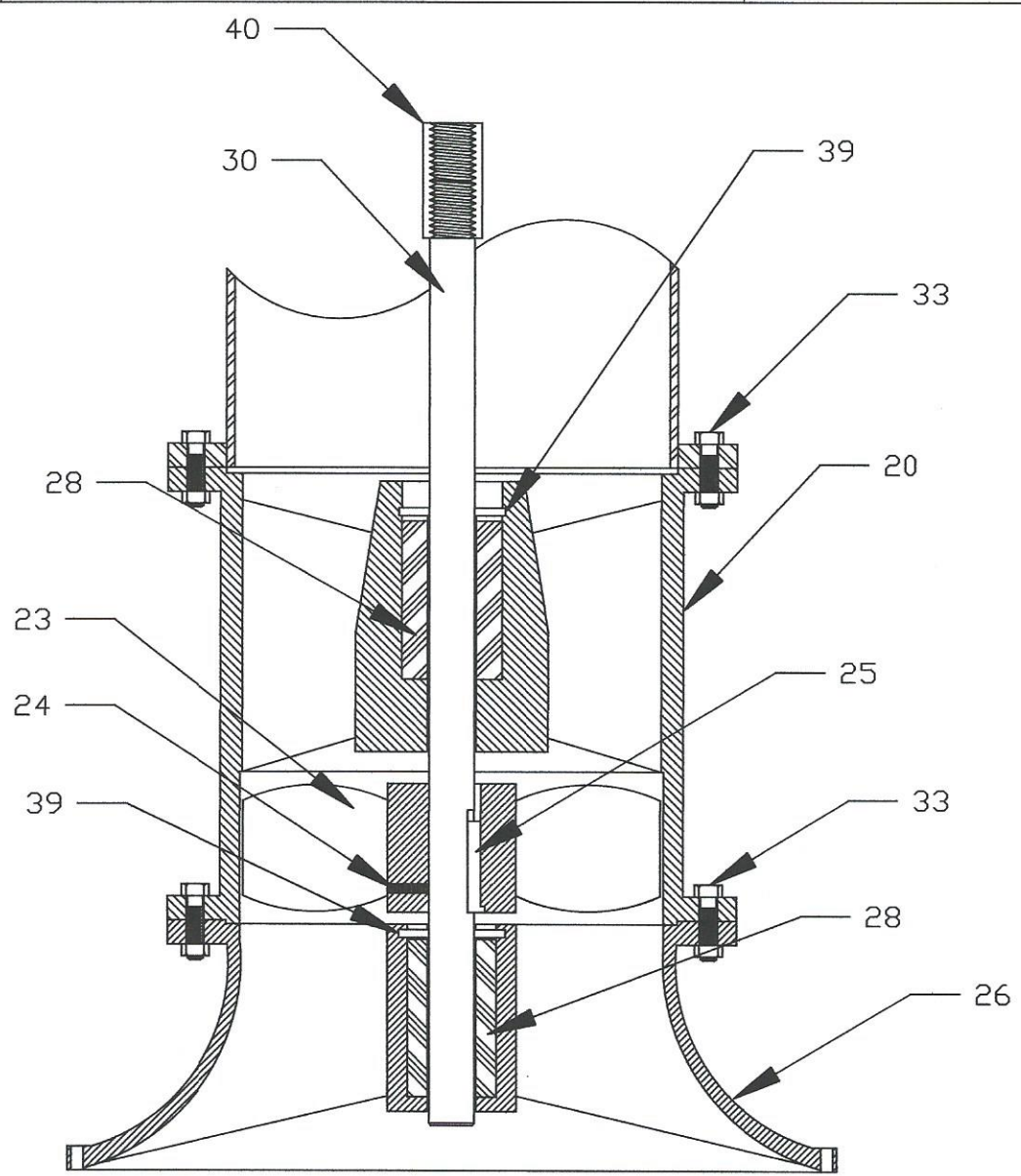

AXIAL FLOW PUMP BOWL ASSEMBLY
SINGLE STAGE - PRODUCT LUBRICATED

THE LO-LIFT PUMP COMPANY, INC 208 NORTH RAILROAD AVENUE WELSH, LOUISIANA 70591		CUSTOMER	
JOB #		CUST. ORDER#	
DATE	REV.# DATE	DATE APP.	BY
DRAWN BY	APP. BY	CAD#	